



# ∅70x20 mm

San Ace C70 9TD type

## General Specifications

- Material ..... Motor case: Aluminum, Impeller: Plastic (Flammability: UL 94V-0)
- Expected life ..... See the table below. (L10 life: 90% survival rate for continuous operation in free air at 60°C, rated voltage) Expected life at 40°C is for reference only.
- Motor protection function ..... Locked rotor burnout protection, Reverse polarity protection For details, please refer to p. 614.
- Dielectric strength ..... 50/60 Hz, 500 VAC, for 1 minute (between lead wire conductors and motor case)
- Insulation resistance ..... 10 MΩ min. at 500 VDC (between lead wire conductors and motor case)
- Sound pressure level (SPL) ..... A-weighted sound pressure level (SPL) at 1 m away from the air inlet.
- Storage temperature ..... -30 to +70°C (Non-condensing)
- Lead wire ..... ⊕Red ⊖Black  Sensor Yellow  Control Brown
- Mass ..... 90 g

## Specifications When the optional inlet nozzle (109-1106) is mounted.

The models listed below **have a pulse sensor with PWM control.**

Model no.	Rated voltage [V]	Operating voltage range [V]	PWM duty cycle [%]	Rated current [A]	Rated input [W]	Rated speed [min <sup>-1</sup> ]	Max. airflow [m <sup>3</sup> /min] [CFM]	Max. static pressure [Pa] [inchH <sub>2</sub> O]	SPL [dB (A)]	Operating temperature [°C]	Expected life [h]
9TD12P6G001	12	10.8 to 13.2	100	1.0	12	9200	1.13 39.9	560 2.24	61	-20 to +70	40000/60°C (70000/40°C)
			20	0.1	1.2	2000	0.23 8.1	25 0.10	30		

\* PWM frequency is 25 kHz. Models without ratings for 0% PWM duty cycle have zero speed at 0%. When control terminal is open, speed is the same as at 100% duty cycle.

Note: Max input is 12.6W at rated voltage.

## Airflow - Static Pressure Characteristics / PWM Duty - Speed Characteristics Example

**9TD12P6G001** With pulse sensor with PWM control

PWM duty cycle

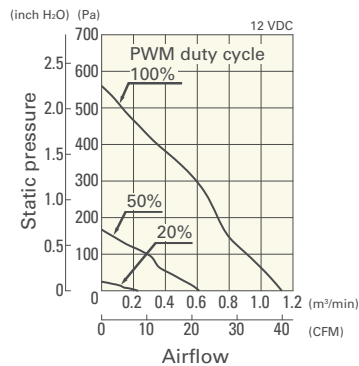

Operating voltage range

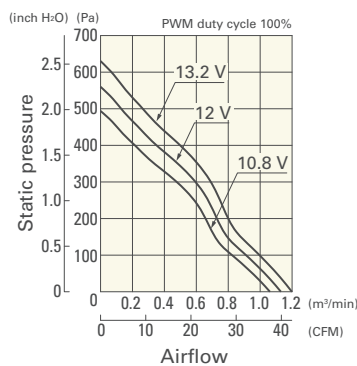

PWM duty - Speed characteristics example

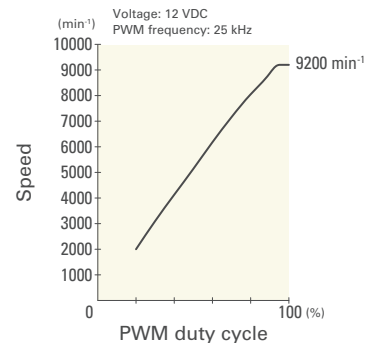

**Dimensions (unit: mm)**

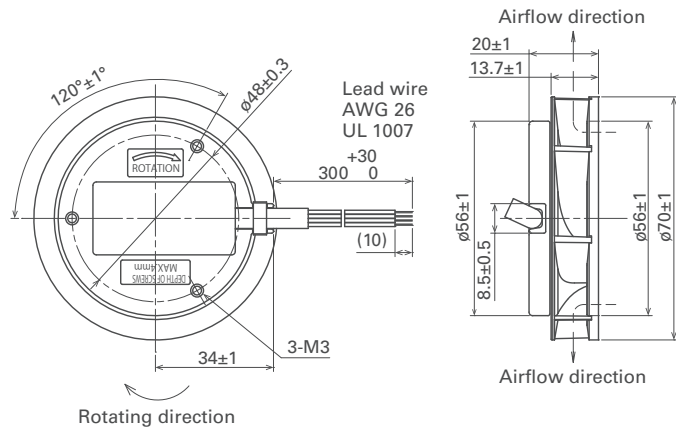

**Reference Dimensions of Mounting Holes and Vent Opening (unit: mm)**

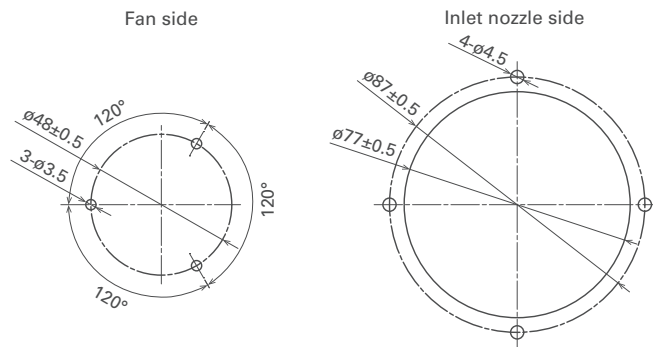

**Reference Diagram for Mounting (unit: mm)**

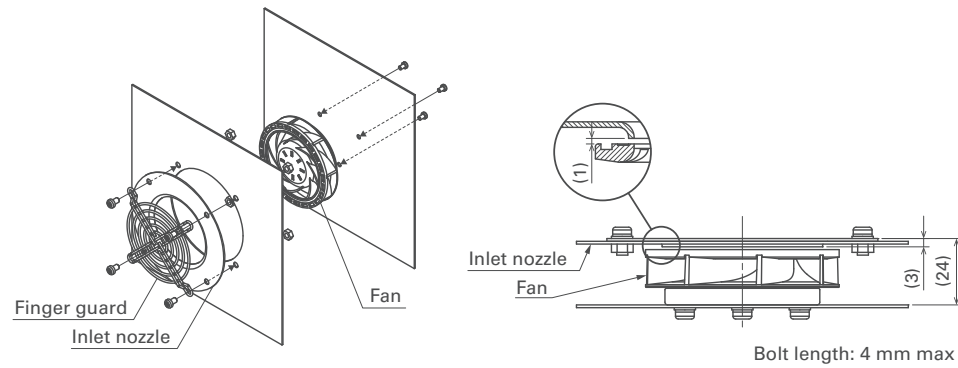

**Options**

Finger guards page: p. 598  
Model no.: 109-1128

Inlet nozzle page: p. 603  
Model no.: 109-1106

DC  
Centrifugal Fan  $\phi 70$  mm