

PRELIMINARY SPEC

Features

- MECHANICALLY AND SPECTRALLY MATCHED TO THE PHOTOTRANSISTOR.
- AVAILABLE ON TAPE AND REEL.
- PACKAGE: 500PCS / REEL.
- MOISTURE SENSITIVITY LEVEL : LEVEL 3.
- ROHS COMPLIANT.



Notes:

1. All dimensions are in millimeters (inches).
2. Tolerance is $\pm 0.2(0.008")$ unless otherwise noted.
3. Specifications are subject to change without notice.

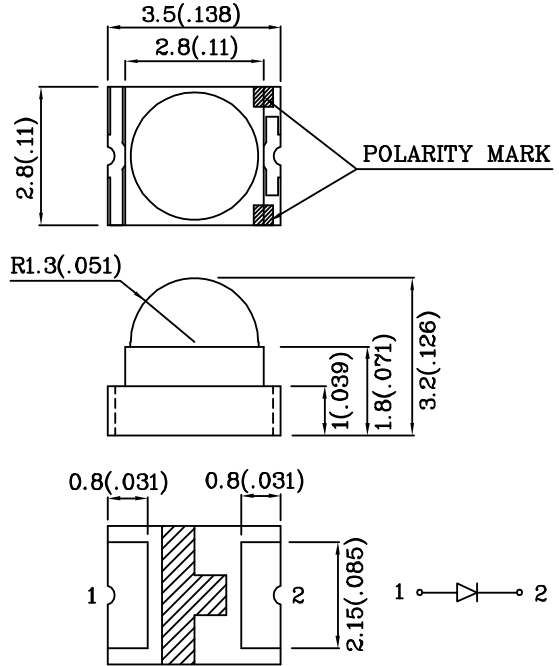

Absolute Maximum Ratings (TA=25°C)		TNI (GaAs)	Unit
Reverse Voltage	V _R	5	V
Forward Current	I _F	50	mA
Forward Current (Peak) 1/100 Duty Cycle 10us Pulse Width	i _{FS}	1.2	A
Power Dissipation	P _T	80	mW
Operating Temperature	T _A	-40 ~ +85	°C
Storage Temperature	T _{stg}	-40 ~ +85	

Operating Characteristics (TA=25°C)		TNI (GaAs)	Unit
Forward Voltage (Typ.) (I _F =20mA)	V _F	1.2	V
Forward Voltage (Max.) (I _F =20mA)	V _F	1.6	V
Reverse Current (Max.) (V _R =5V)	I _R	10	uA
Wavelength Of Peak Emission (Typ.) (I _F =20mA)	λ _P	940	nm
Spectral Line Full Width At Half-Maximum (Typ.) (I _F =20mA)	Δλ	50	nm
Capacitance (Typ.) (V _F =0V, f=1MHz)	C	90	pF

Part Number	Emitting Material	Lens-color	Luminous Intensity Po (Mw/sr) @20mA		Wavelength nm λ _P	Viewing Angle 2θ 1/2
			min.	typ.		
XZTNI45W-2	GaAs	Water Clear	1.6	3.8	940	40°
Published Date : JUL 10,2008 Drawing No : XDSA6055 V2 Checked : B.L.LIU P.1/4						

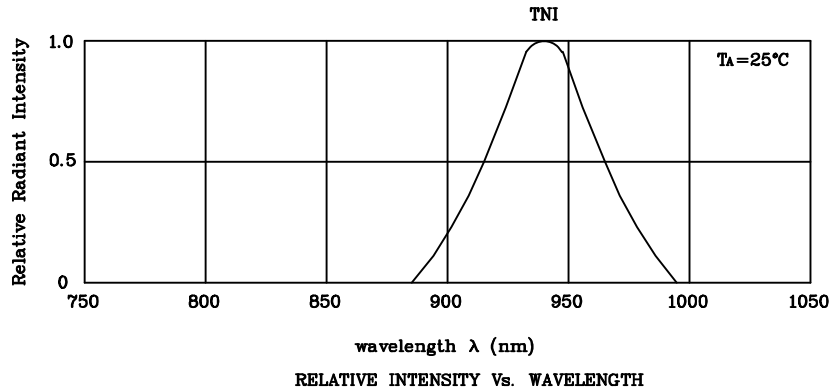

❖ TNI

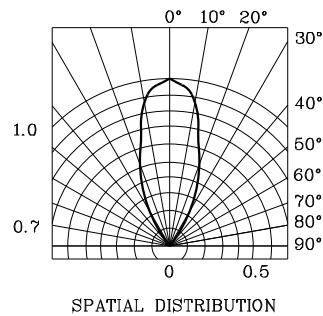
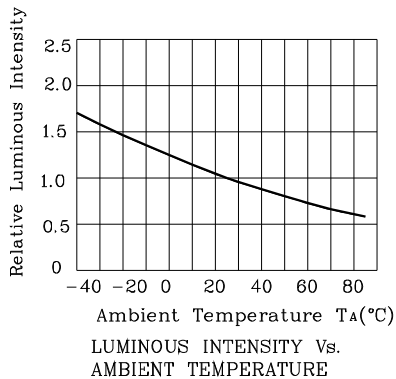
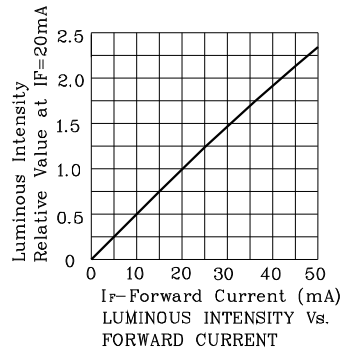
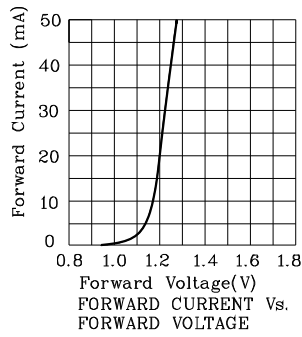

Reflow Soldering Profile For Lead-free SMT Process.

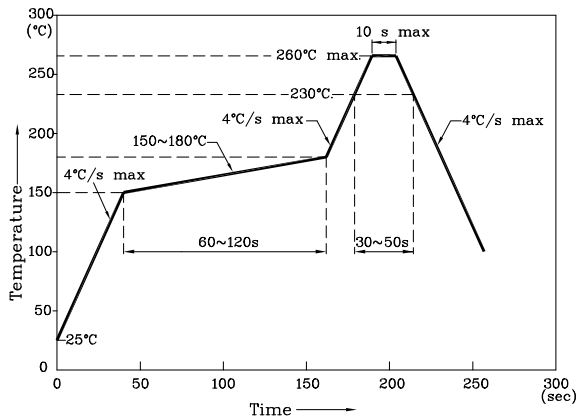

NOTES:

1. Maximum soldering temperature should not exceed 260°C.
2. Recommended reflow temperature: 145°C-260°C.
3. Do not put stress to the epoxy resin during high temperatures conditions.

❖ Recommended Solering Pattern
(Units : mm; Tolerance:± 0.1)

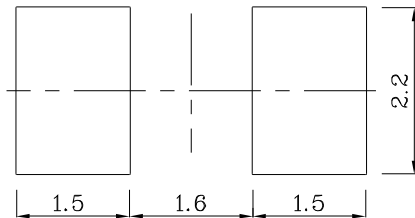

❖ The device has a single mounting surface. The device must be mounted according to the specifications.

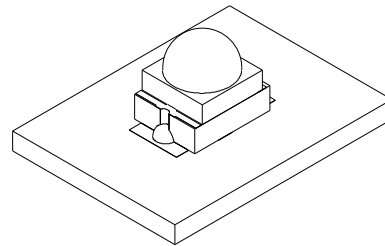

❖ Tape Specification (Units : mm)

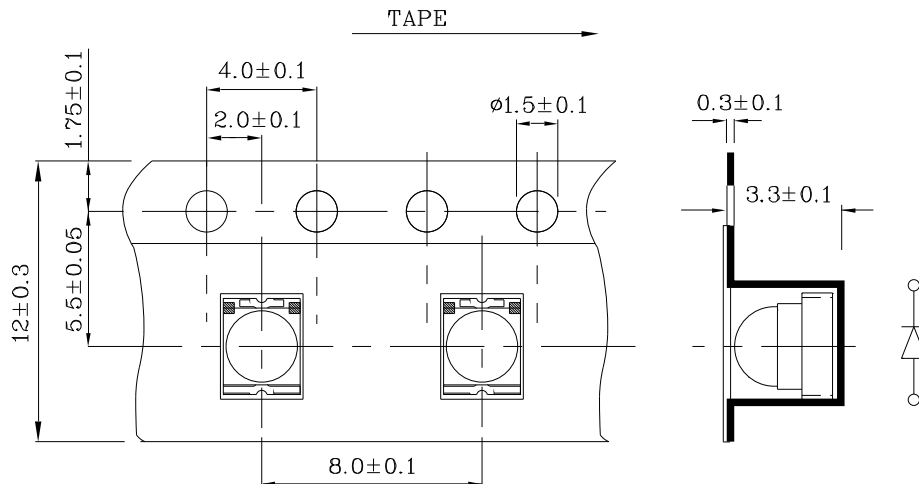

Remarks:



If special sorting is required (e.g. binning based on forward voltage or radiant intensity/ luminous flux), the typical accuracy of the sorting process is as follows:



1. Radiant Intensity/ luminous flux: +/-15%
2. Forward Voltage: +/-0.1V

Note: Accuracy may depend on the sorting parameters.

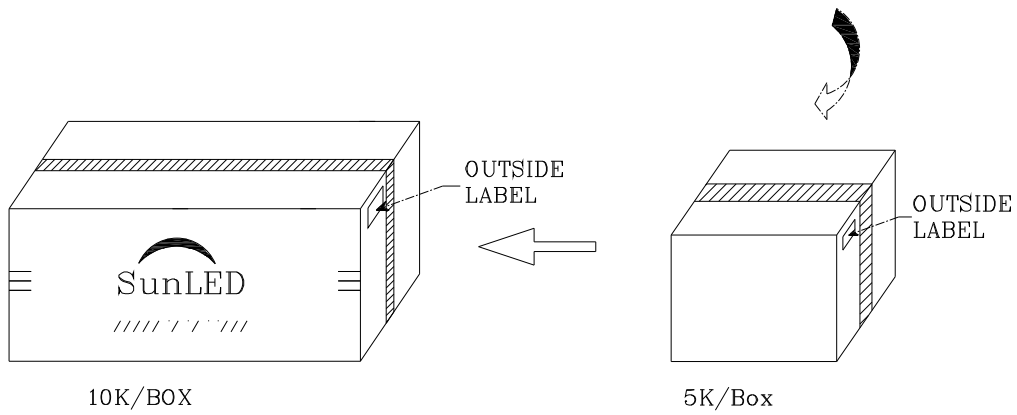
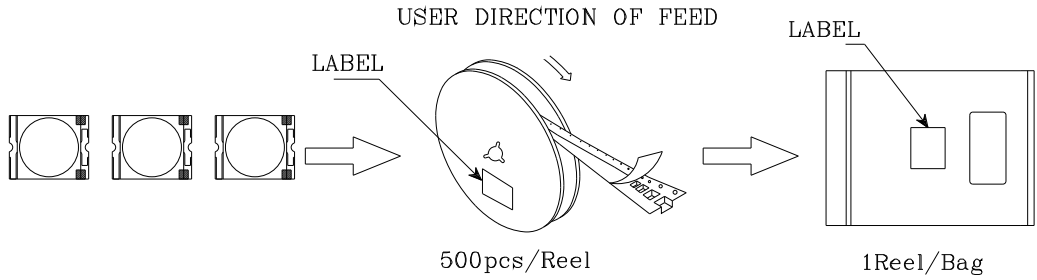
PACKING & LABEL SPECIFICATIONS

XZTNI45W-2

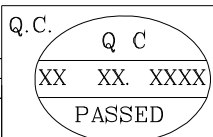
	
P/NO : XZxx45x-2	
QTY : 500 pcs	CODE: XXX
S/N : XX	
LOT NO:	
 XXXXXXXXXXXXXXXXXXXXX	
RoHS Compliant	