

**Finger guards** Dimensions (unit: mm)

Increases safety by preventing foreign objects from entering fans. Fans can be used with little effect on airflow and static pressure. For use in environments subject to water splashes, cation electroplating models are recommended.

**92 mm sq. type**

Model no.	Surface treatment	Mass (g)
109-099C	Nickel-chrome plating (silver)	22

**ø92 mm type**

Model no.	Surface treatment	Mass (g)
109-1147	Nickel-chrome plating (silver)	23

**92 mm sq., ø100 mm type**

Model no.	Surface treatment	Mass (g)
109-099E	Nickel-chrome plating (silver)	29
109-099H	Cation electroplating (black)	

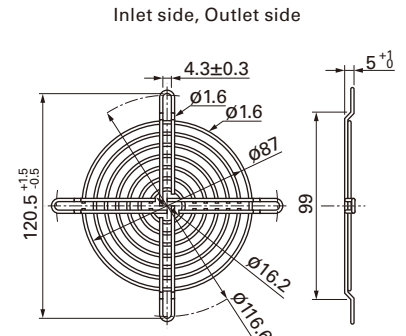
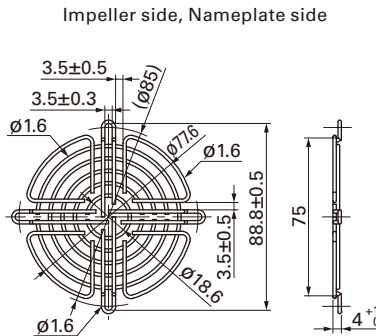
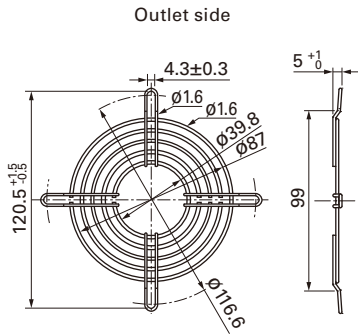

**Mounting example**

Axial fan

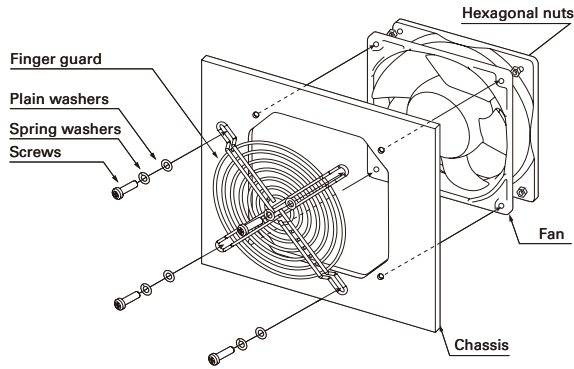

Centrifugal fan

